

Scheme Update – September 2020

Visit our website to see the latest video drone footage of the scheme

Stafford Western Access Route will provide additional highway capacity to the west of Stafford and will enable the removal of through traffic from the town centre, creating improved conditions for bus services, pedestrians and cyclists. It is also essential to the delivery of housing, new business and leisure development.

Introduction

Since our last update we have been making great progress, surfacing works are complete at Martin Drive and kerbs are being installed along the new road Unicorn Way. Surfacing works are almost complete on Doxey Road up to the new roundabout and the retaining wall works at Madford are also complete.

What are we doing now?

The new road section between Sainsbury's and Madford Retail Park is progressing well, most of the works you have seen so far have been happening underground with the piling works and concrete pours. We are currently just completing the final reinforced concrete crosshead installation ready for mid October when you will see beams arriving on site, these will be used as part of the bridge structure running over the River Sow.

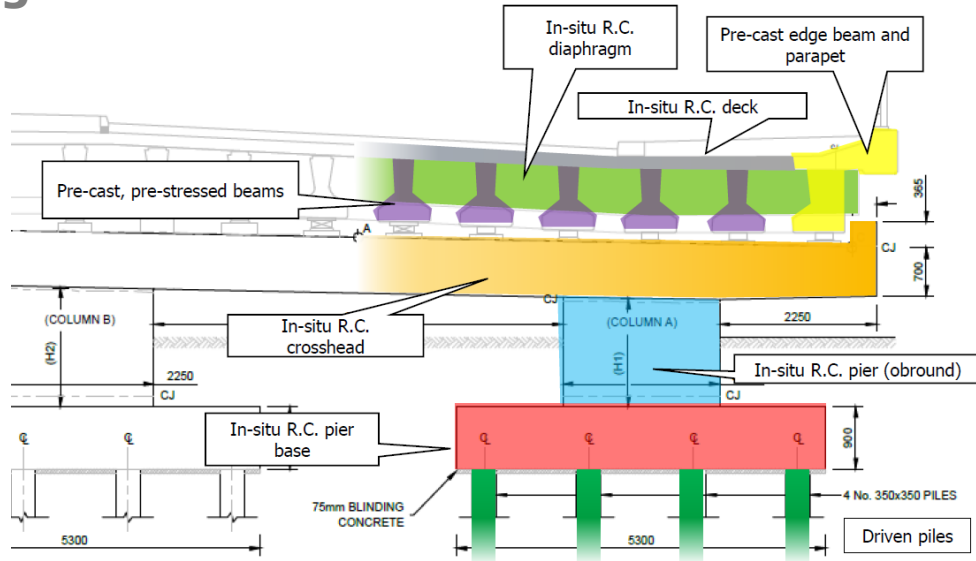

FACTS

- All beams will be manufactured and then transported to site over a 2 week period from Nottinghamshire
- A total of **72** Beams will be installed
- Beams weigh up to **58** tonne
- We will be aiming to install **6** beams a day over a 2 week period
- A **500** tonne crane is required to install 6 beams across the river

Key Milestones

A34 Madford Retail Park
Access & Egress
diversion

Installation of bridge
beams across River
Sow

Surfacing
works on
Unicorn Way

Xmas Closure
21st December – 1st January

Completion of
bridge decks

September

October

November

December

*Dates in accordance with current programme and could be subject to change