

Staffordshire Procurement Conference

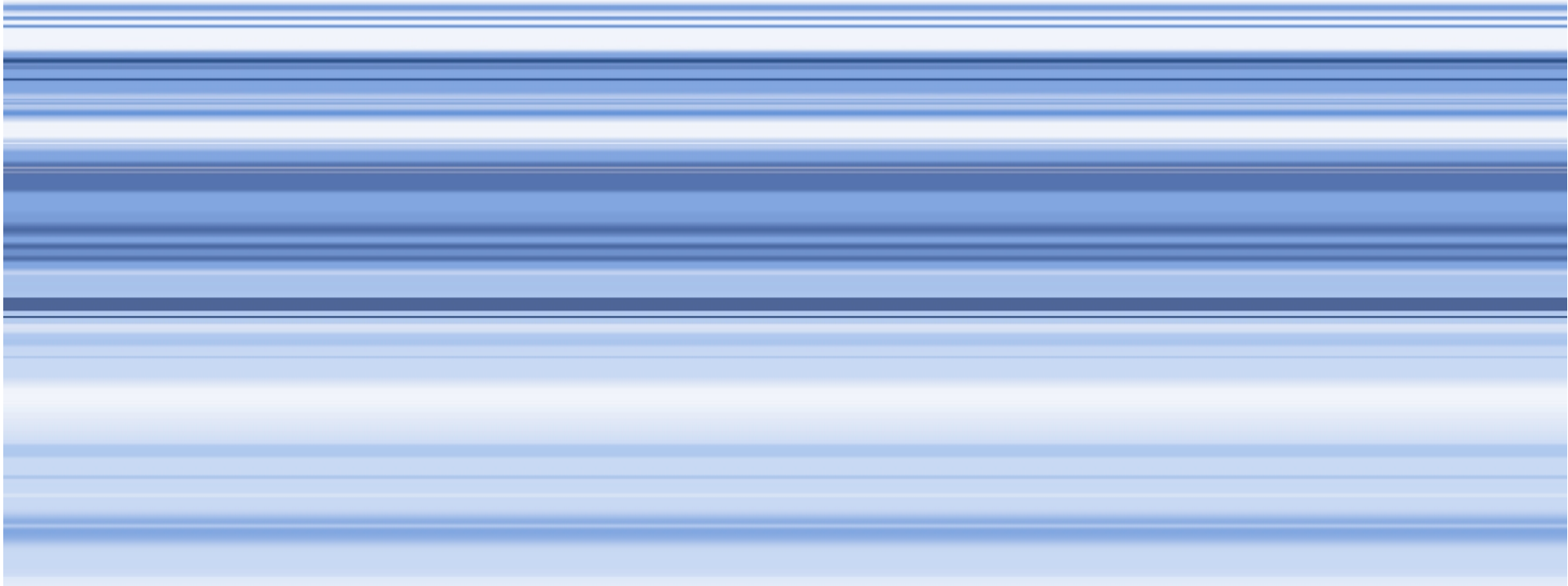

Cassie Clifford-Wareham
Commercial Delivery Manager
Markets & Collaborative Procurement



Who are we?

- **Independent office of The Treasury**
- **Established in 2000 as part of Peter Gershon's Transforming Government Procurement Report**
- **Made up of a number of departments within Treasury**
- **OGC tasked with:**
 - Helping Government deliver best value from its spending (£175bn per annum)
 - Driving major change and creating best practice in procurement across Government

The Office of Government Commerce

Under Nigel Smith's leadership, OGC built on this agenda through its own Strategic Review, in order to focus on:

What does Government need?

What is OGC's role in meeting the need?

By 2010 /11 we aim to:

- Help achieve significant savings in procurement and estates
- Improve large project delivery outcomes
- Have identified capability gaps and have measures in place to close them
- Lead delivery of environmental sustainability targets
- Institutionalise best practice sharing
- Support wider policy objectives

OGC departments & objectives

- **Centre of Excellence in Sustainable Procurement:**
Providing leadership on and a central focus for environmental sustainable procurement and operations across the government estate
- **Policy & Standards:**
Supporting the delivery of Government policy goals through best practise principles on value for money, collaboration and sustainability.
- **Government Procurement Service (GPS):**
Supporting procurement professionals across government and improving central Government capability in procurement, project, programme management and estates

OGC departments

- **Programmes & Projects:**

Providing the required toolkits necessary for delivering projects to time, quality and cost, realising benefits

- **Government Estate Transformation:**

Getting the best from Government estate which ensures efficient management of property assets

- **Markets & Collaborative Procurement (M&CP):**

Championing and facilitating collaboration across the wider public sector for the delivery of value for money savings from third party spend

Public sector challenges

Roots Review: highlighted the need for public sector organisations to actively promote greater compliance and uptake to collaborative strategies

Operational Efficiency Programme (OEP)

The OEP report focuses on need for **clear leadership** to deliver a coordinated approach to procurement within the wider public sector to **achieve further savings** but **maintain sustainable public finances** i.e. continued investment in frontline services

- 80% of central government working collaboratively by 2010/11
- 50% of wider public sector working collaboratively by 2010/11

Collaboration is key to achieving the Government's stretching savings target of £35bn by 2010-11

How will MCP help achieve this?

Through 8 common procurement categories:



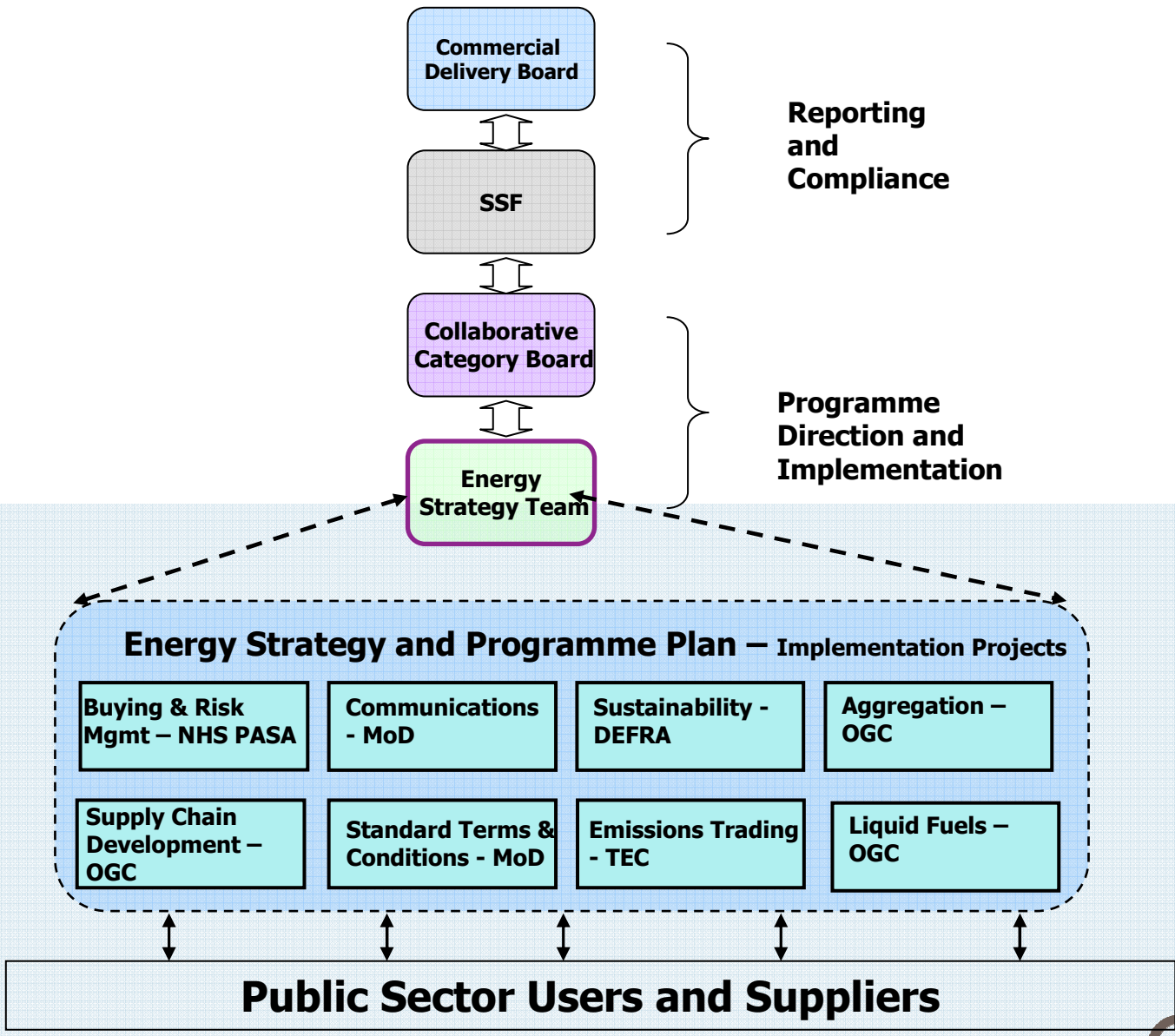

The Pan Government Energy Project

- Collaborative procurement project set up in 2007 and sponsored by MOD
- Covering £3.8bn energy spend in the public sector
- Brings together major public sector energy buyers and customers through the Energy Strategy Team
- Developing best practice in energy procurement and promoting collaboration across public sector
- Developed public sector energy strategy for gas, electricity and liquid fuels

Who's involved?

Local Government:

- Eastern Shires Purchasing Organisation
- Laser
- North Eastern Purchasing Organisation
- West Mercia Supplies
- Yorkshire Purchasing Organisation
- London Energy Project
- Regional Improvement and Efficiency Partnerships

Education

- The Energy Consortium
- Department for Children, Schools and Families
- Department for Innovation, Universities & Skills

Central Government:

- Office of Government Commerce
- Buying Solutions (but cover all sectors)
- Ministry of Defence
- Department of Energy and Climate Change
- Department for Work and Pensions
- Department for Business, Enterprise and Regulatory Reform
- HM Revenue & Customs

Health

- NHS Purchasing and Supply Agency

Devolved Administrations

- Procurement Scotland
- Value Wales

Represents >70%
of public sector
volumes

How does the public sector buy energy now?

£3.8billion

KEY: Grey boxes = private sector
 Green boxes = Public sector
 Green lines = flexible procurement
 Orange lines = fixed procurement

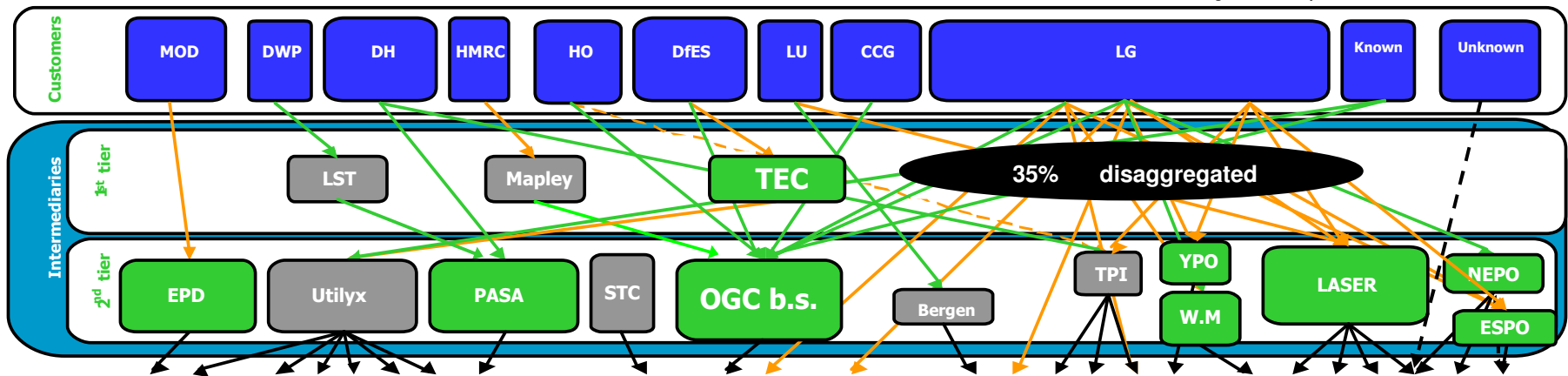

250 OJEUS

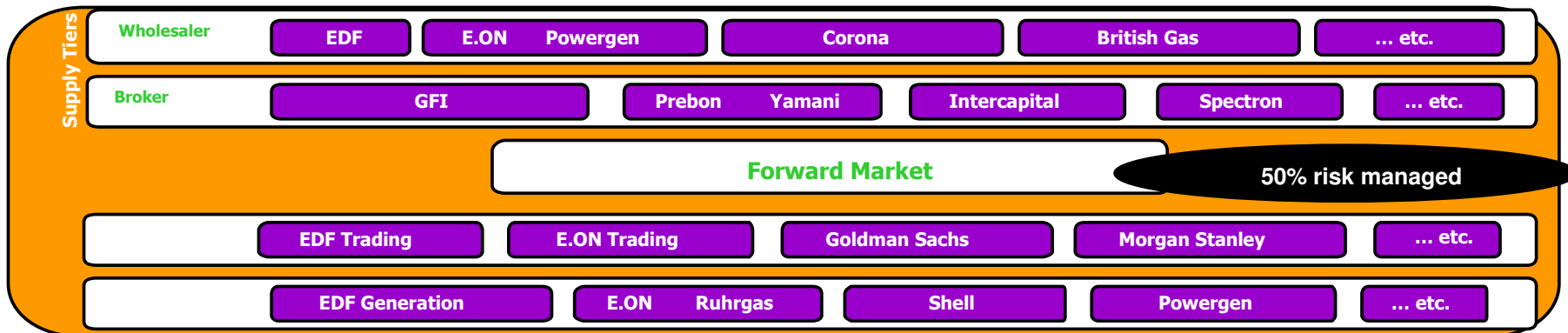

Successes to date

- **Buying Solutions, NHS PASA, LASER, ESPO, NEPO and MOD have recommended solutions. TEC provisionally recommended**
- **42% volumes in recommended solutions (as at April 09)**
- **65% public sector volumes in collaborative arrangements (as at April 09)**
- **Publication of energy buying guides**
- **Energy - exceeded £100m savings target (£134m)**
- **Pan government IT power management framework (DCMS) awarded in May 2008**
- **Automated Meter Reading and Voltage Reduction initiatives**
- **Sustainability - exceeded £2m savings target (£5.8m)**
- **PASA & Buying Solutions joint Liquid Fuels purchase (£200k savings)**

Future objectives

- **74% of Public Sector in Collaborative Agreements by Oct 09**
- **% Public Sector in recommended solutions forecast:**
 - Oct 09 Total = >50%, Apr 10 Total = >60%**
- **£300m Savings target by 2010/11**
- **First ever Public Sector Power Purchase Agreement (PPA)**

Things to remember!

- **OGC is here to help every procurer in the public sector and it's services are free!!**
- **OGC works with public sector organisations to benefit those organisations.**
- **OGC will help every organisation to meet procurement and sustainability targets.**
however –

You have to be in it, to win it!!

Thank you

**Cassie Clifford-Wareham
Commercial Delivery Manager
Markets & Collaborative Procurement**

OGC